

# PI

*Intelligent Pilot Operated  
Pressure Regulator*



# GASCAT

APPLICATION

The PI regulator has been developed by the Engineering Department of Gascat to provide a very accurate pressure control even if the inlet pressure and / or the flow varies. The PI was designed to be used in natural gas transmission and distribution systems, air plants services, large commercial and industrial establishments.

OPERATION PRINCIPLE

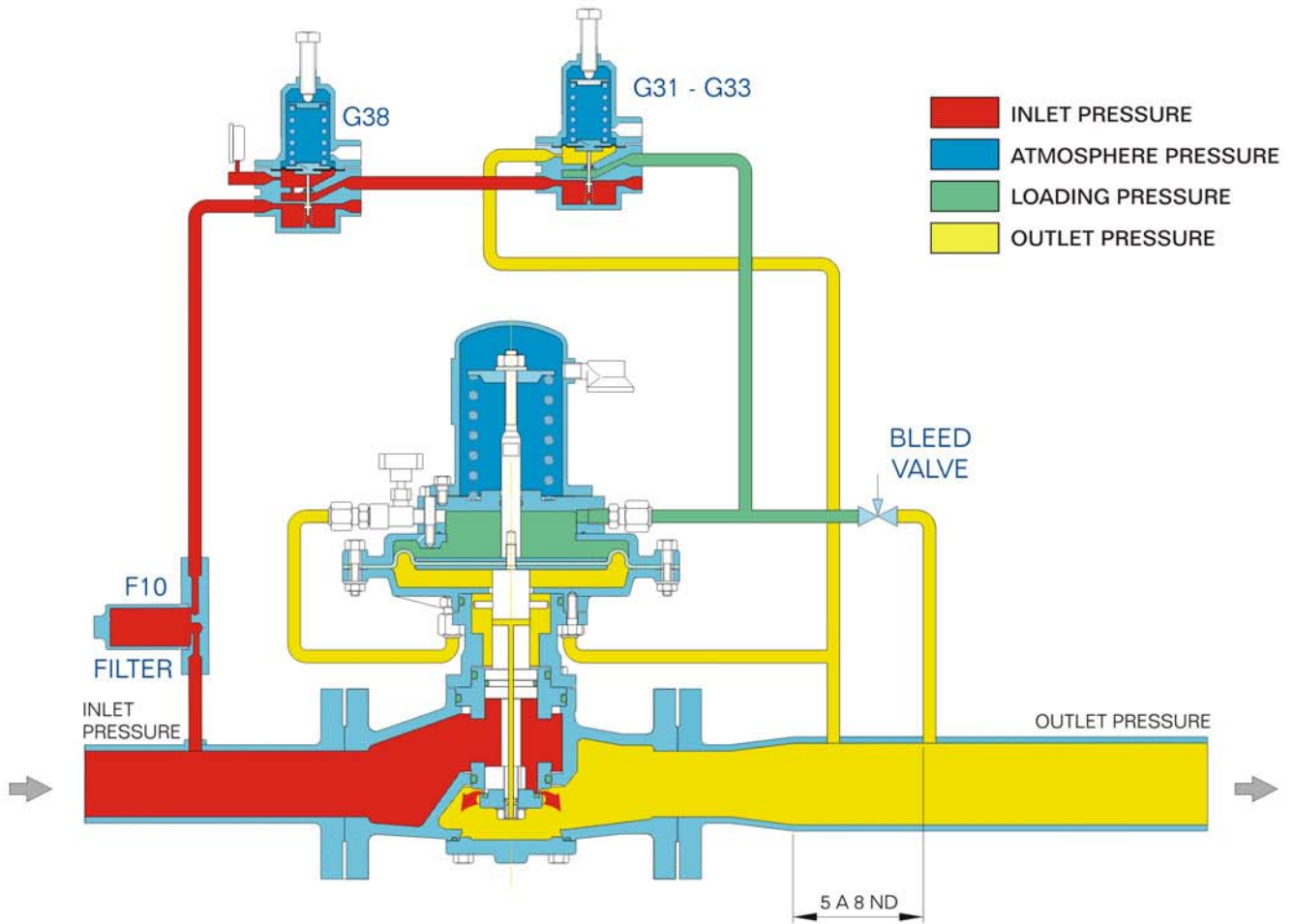

The PI regulator works on the principle of the pressure difference between the piloting chambers.

In the absence of gas in the system, the main valve is kept in the closed position by the action of the spring into the upper chamber of main valve actuator that pushes the plug against the seat.

If there is gas flow, the outlet pressure feeds the lower chamber pilot (G-31 / G-33) and the lower chamber of the main valve actuator, compares with the spring set-point adjusted in the pilot (G-31 / G-33).

If the outlet pressure is lower than the set-point, the pilot will supply the upper chamber of the main valve with more loading pressure. Thus, the pressure in the upper chamber of the main valve actuator will be larger than lower chamber, therefore the main valve will open allowing gas flow until achieve the pressure set-point. As soon as the pressure set-point is achieved, the main valve keeps this position.

The response speed of the system is controlled by the bleed valve located downstream the pilot. When the differential pressure between inlet pressure and the pressure set-point is greater than 4 bar, it is necessary to use the G-38 pre-regulator. The pre-regulator must supply the pilot (G-31 / G-38) with 2 to 4 bar higher than the pilot set-point.

## TECHNICAL DATA

Component		Material	G-31 and G-33 Pilot Springs Regulation Range			
Main Regulator	Body	Cast Steel	Spring Code	Spring Color	Spring Range	Pilot Model
	Diaphragm Case	Ductile Iron	01.49.61	Silver	0.7 - 2.8 bar	G-31 (150#)
	Valve Stem	Stainless Steel	01.49.65	Green	2.0 - 6.5 bar	G-31 (150#)
	Orifice / Valve	Brass or Stainless Steel	01.49.64	Red	5.0 - 14.0 bar	G-31 (150#)
			01.49.33	Brown	7.0 - 18.3 bar	G-31 (150#)
	Diaphragm / Soft seat / Seals	Buna N	01.49.33	Brown	14.0 - 37.0 bar	G-33 (300#)
01.49.59			Black	28.0 - 40.0 bar	G-33 (300#)	
Pilot	Body / Cover	Aluminum	Accuracy and Lock-up Features - According to DIN EN 334			
	Diaphragm / Soft seat / Seals	Buna N				
	Trim	Stainless Steel	AC	SG	SZ	
			up to ± 1%	up to ± 5%	10% to ± 2.5%	

Note: Tightness (ANSI B 16.104) – Class VI.

Connections	Nominal Diameter
Flange ANSI B-16.5 150# or 300# rating class	1", 2", 3" and 4"

### Notes:

- DIN PN 16 or PN 40 Flanges are available under request.
- NPT connection available only for 1" ND
- Maximum Inlet Pressure: 50 bar (for class 300#)
- Flange Connection: According ANSI B-16.5
- Outlet Pressure: 0.7 - 40 bar
- Minimum Differential Pressure between pilot supply and outlet pressure: 1.0 bar
- Operating Temperature: -20° to 60 ° C
- Balanced valve gives excellent control over large variation of inlet pressure
- Tight shut-off on zero flow (positive lock-up)
- Fail Position: Closed (std) / Open (also available)
- Other body materials or diaphragm and seals are available under request.
- To Differential Pressure > 4 bar, it is necessary to use pre-regulator (G-38 model). In this situation, the G-38 set-point must be 2 to 4 bar higher than the main valve outlet pressure.

## SIZING FORMULAS

Sub-Critic Flow	Critic Flow
$P_2 / P_1 \geq 0,53$	$P_2 / P_1 < 0,53$
$Q = KG \cdot \sqrt{P_2 \cdot (P_1 - P_2)}$	$Q = (KG \cdot P_1) / 2$

where:

Q = Maximum regulator flow (Nm<sup>3</sup>/hr)

KG = Regulator coefficient (See table)

P<sub>1</sub> = Regulator inlet pressure (bar - abs)

P<sub>2</sub> = Regulator outlet pressure (bar - abs)

### Notes:

1. We suggest that the regulator sizing calculation considers a minimum safety factor of 20% above the calculated value.
2. For application with other gases, the calculated flow shall be converted to an equivalent flow in natural gas, using the table as follows:



Gas	Specific Gravity ( Kg/m <sup>3</sup> )	Correction Factor	Other Gases
Air	1,29	0,77	Correction Factor = $\sqrt{\frac{0,78}{\text{Spec. Gravity}}}$
Nitrogen	1,25	0,79	
Propane	2,02	0,62	
Butane	2,70	0,53	

Flow Coefficient (Kg)				
Nominal Diameter	1"	2"	3"	4"
K <sub>G</sub>	440	1050	2900	5100
K <sub>G</sub> restricted	280	700	1400	3000

Dimensions (mm) & Weight (kg)										
ND	A (RF)		B		C		D		Weight (kg)	
	150#	300#	150#	300#	150#	300#	150#	300#	150#	300#
1"	203	203	210	210	395	395	215	215	25	26
2"	267	267	210	210	428	428	255	255	34	35
3"	298	318	256	256	441	441	133	133	69	71
4"	352	368	282	282	610	475	175	175	85	89

### INSTALLATION

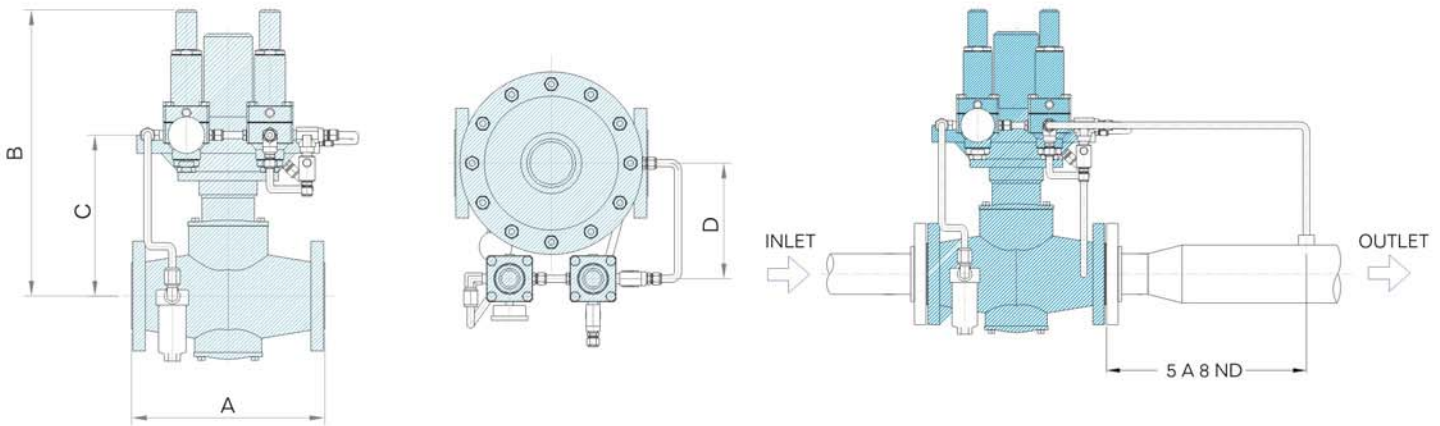

### CERTIFICATIONS

ISO 9001

ASME - U-STAMP

NATIONAL BOARD



#### Factory

Rodovia SP 73, nº 1141 - Bairro Pimenta

Indaiatuba - SP - Brazil - Zip Code 13.347-390

Phone: (55 19) 3936-9300 - Fax: (55 19) 3935-6009

<http://www.gascat.com.br>

e-mail: [sales@gascat.com.br](mailto:sales@gascat.com.br)

#### Representative/Distributor